



WHEELS INDIA LIMITED

(TSF Group Company)

**Air Suspension -
The Ride thus far....**

WHEELS INDIA LIMITED

Srivats Ram, MD, Wheels India

Why do we need Suspension?



Isolate road shocks from the vehicle chassis



Enhance road grip, acceleration, braking, and cornering safety



Advantages of an Air Suspension System

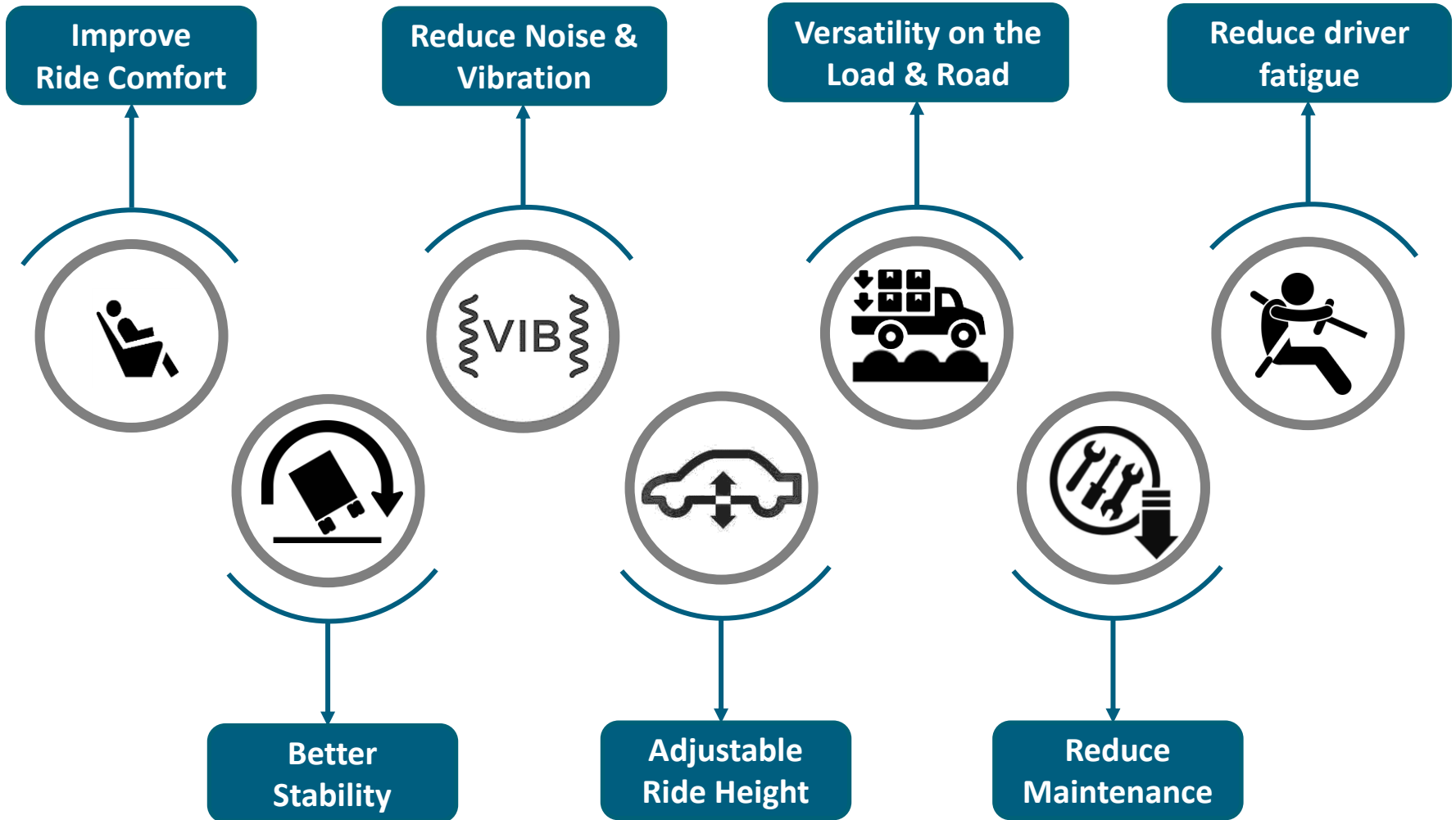

Ride Map Comparison

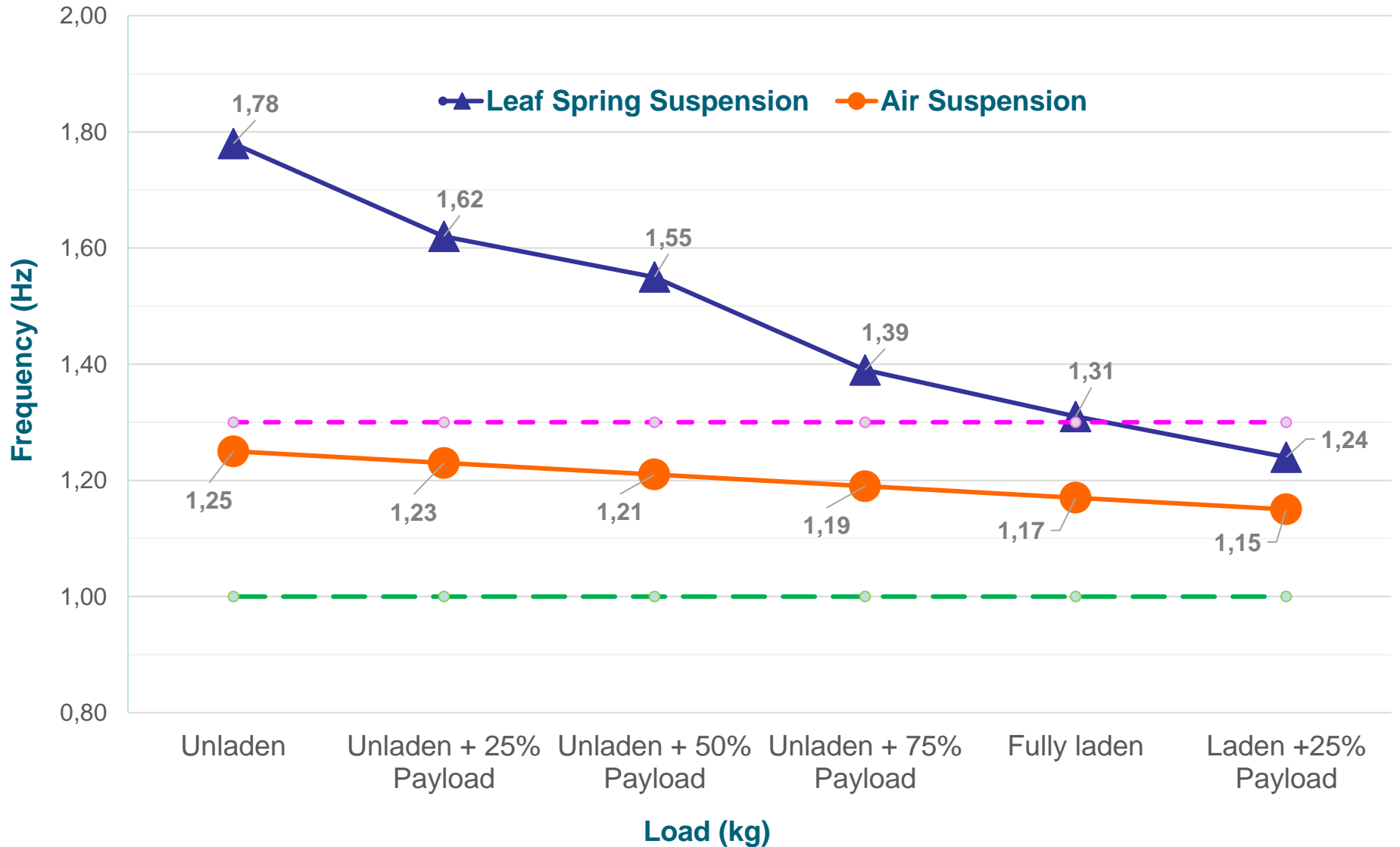

Our Journey with Air Suspension

- Our first steps - Dunlop technology PTC buses 1988
- In the 1990s, re-designing the suspension to suit the Indian road and usage patterns
- In the decade, we supplied close to 1,000 private bus operators with retro-fitted air suspension
- Established and trained a service network across the country
- From 2000, started supplying OEMs, as air suspension was introduced as an option.
- Started fitment to state transport undertakings and helped them define specs and service standards
- Have supplied air suspension systems to over 100,000 buses on Indian roads
- There are a few hundred vehicles on roads in Sri Lanka, Thailand, Mauritius and East Africa.
- Development of ECAS as an alternative.



BUS Application

For Normal Axle

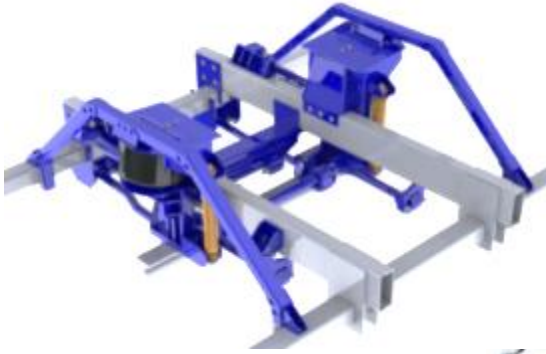

FRONT AIR SUSPENSION
(Axle Rating : 5 Ton to 8 Ton)



Overslung Design



REAR AIR SUSPENSION
(Axle Rating : 10 Ton to 14.7 Ton)

For Deep Drop Axle

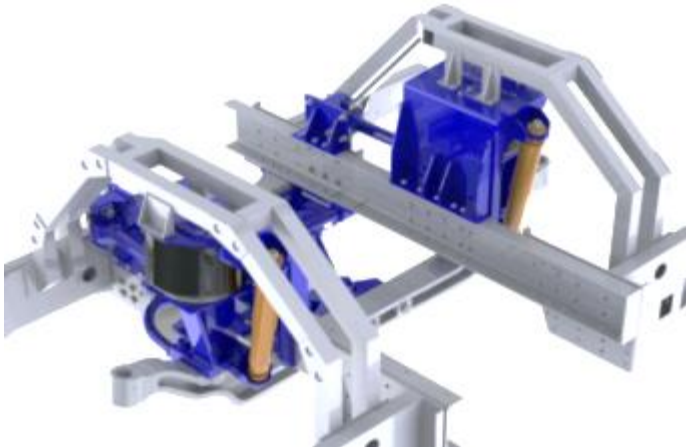

Underslung Design



WIL Air suspension population in Major STU's

100K+
Buses on road

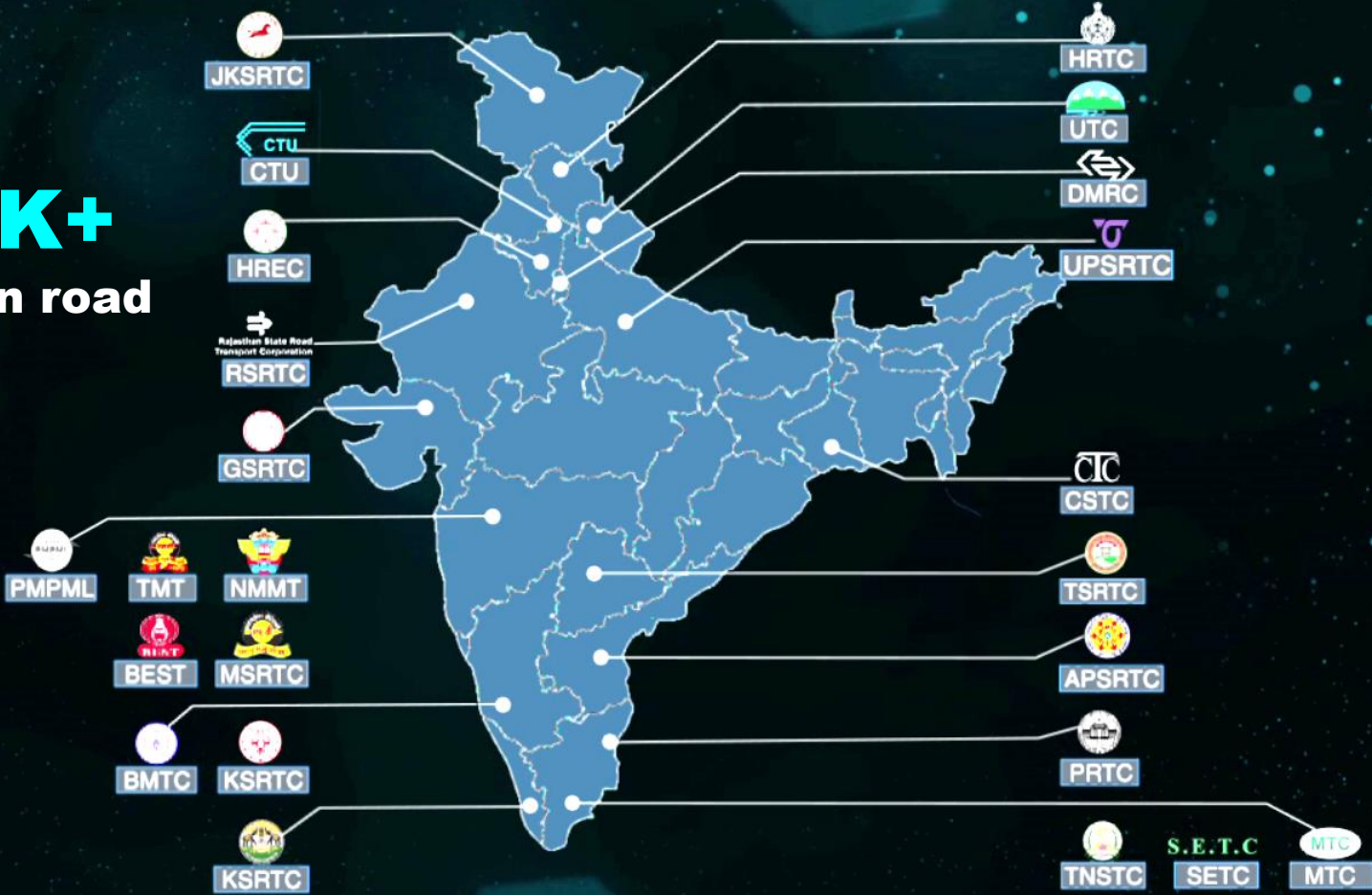

*STU - State Transport Undertaking

Customer Support

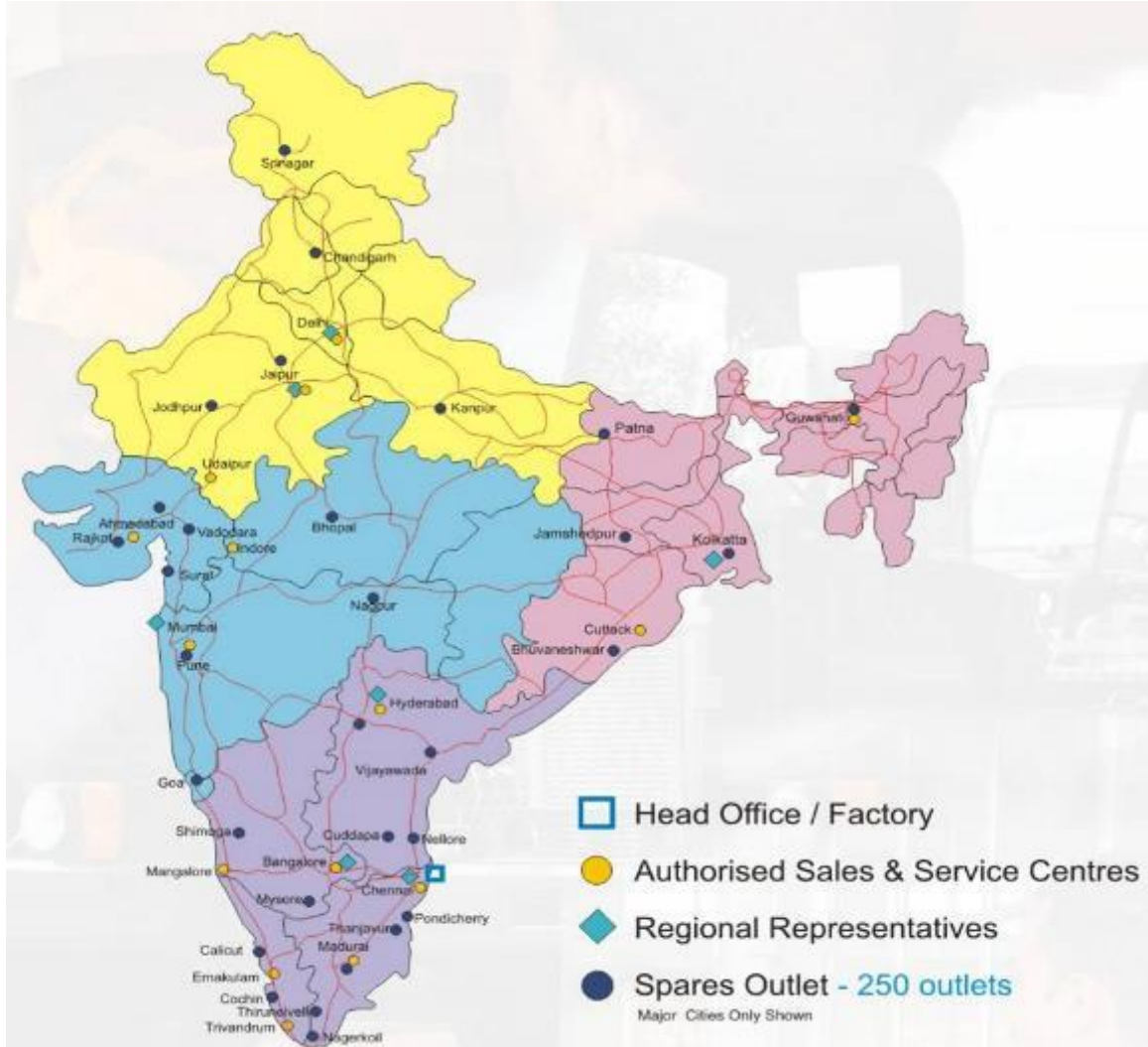

Behind the product lies a continuously expanding support and parts network across the country



Prime Customers



EICHER



SWITCH
MOBILITY



Mahindra

DAIMLER

Major Indian
and Global OEMs



ASHOK LEYLAND

TATA MOTORS

SML
ISUZU



Our Aspirations in Indonesia

- Need a local partner for retro-fitment and service
- Work with local bus body builders in Indonesia
- Need to establish a service network for fitted buses
- Can look at localizing of some non-critical parts, if volumes come





Thank
YOU!

